

DISPLAY | Cabinet Displays

REFRIGERATED DISPLAY CABINETS ▶ 4 SIDED GLASS



GENERAL FEATURES

- Serve-over display case
- Ventilated Cooling
- Evaporator with anti-corrosion treatment
- Automatic compressor cycle defrost
- Digital thermostat with "opening door" and "High temperature" alarm
- Thermopane glasses with black serigraphy
- Rear sliding doors in Thermopane glass
- Adjustable glass shelves (N.3 Pcs)
- Interior LED light (with independent switch)
- Insulated tank with water base foaming
- N.4 Adjustable feet
- Energy efficiency class: C

TECHNICAL SPECIFICATIONS

Capacity	443 L
Temperature	M2 (-1°C-+7°C)
Consumption	11.54 kWh/24h
Rated Power	373 W
Noise level	64 dB(A)
Net Weight	295 Kg
Gross Weight	336 Kg
External Dimensions (WxDxH mm)	1500x780x1380
Internal Dimensions (WxDxH mm)	1400x600x790
Packaging dimensions (WxDxH mm)	1600x860x1580
Loading quantities 20'/40'/40'HQ	7/14/14

CERTIFICATION

CE RoHS



WKR 150



45 mm | M2 -1°C +7°C | ENERGY CLASS C | 3 +25°C/60RH | LED | GAS R290

DETAILS



Digital Thermostat



Rear sliding doors in Thermopane glass



Refrigerated glass shelves

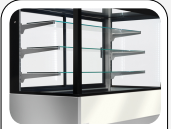

Nightblind (Fabric - Grey color)

PRODUCT DIMENSIONS

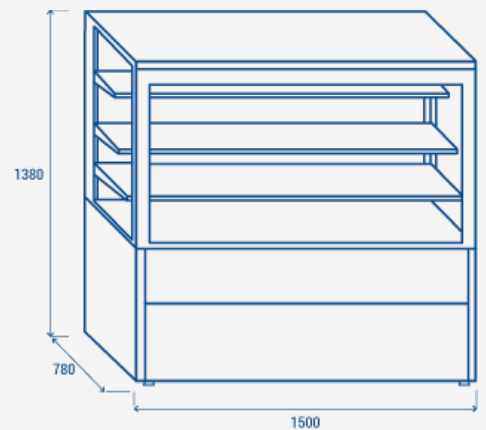

1380

780

1500